

DEPA Air Operated Diaphragm Pumps

Series P

Plastic Pumps Type DL15-PM, DL25-PM, DL40-PM

The new pump generation PM is a further development of DEPA's proven and successful polypropylene pumps series.

The development offers a combination of modern industrial design combined with the daily requirements of pumps, like temperature, chemical resistance and high mechanical strength.

The computer-aided design of the injection moulding achieves a constant high quality with excellent surface finish for low flow resistance and good abrasion resistance.

The result of the new design offers a strong and compact type of construction.

These new DEPA pumps have all the advantages of Air Operated Diaphragm pumps, dry running, self-priming, gentle product handling and the ability to stall against closed discharge lines.

Various options allow a wide variety of applications for the pumps.

Internal and external air valves, ANSI, DIN and JIS flanges and screw connections are available.

For the product wetted parts (diaphragms, valve seats and valve balls) there are several elastomer materials available.

Flow rate max. 9 m³/h at max. 7 bar.

DE/DB-0005-GB / 09.01 / MD

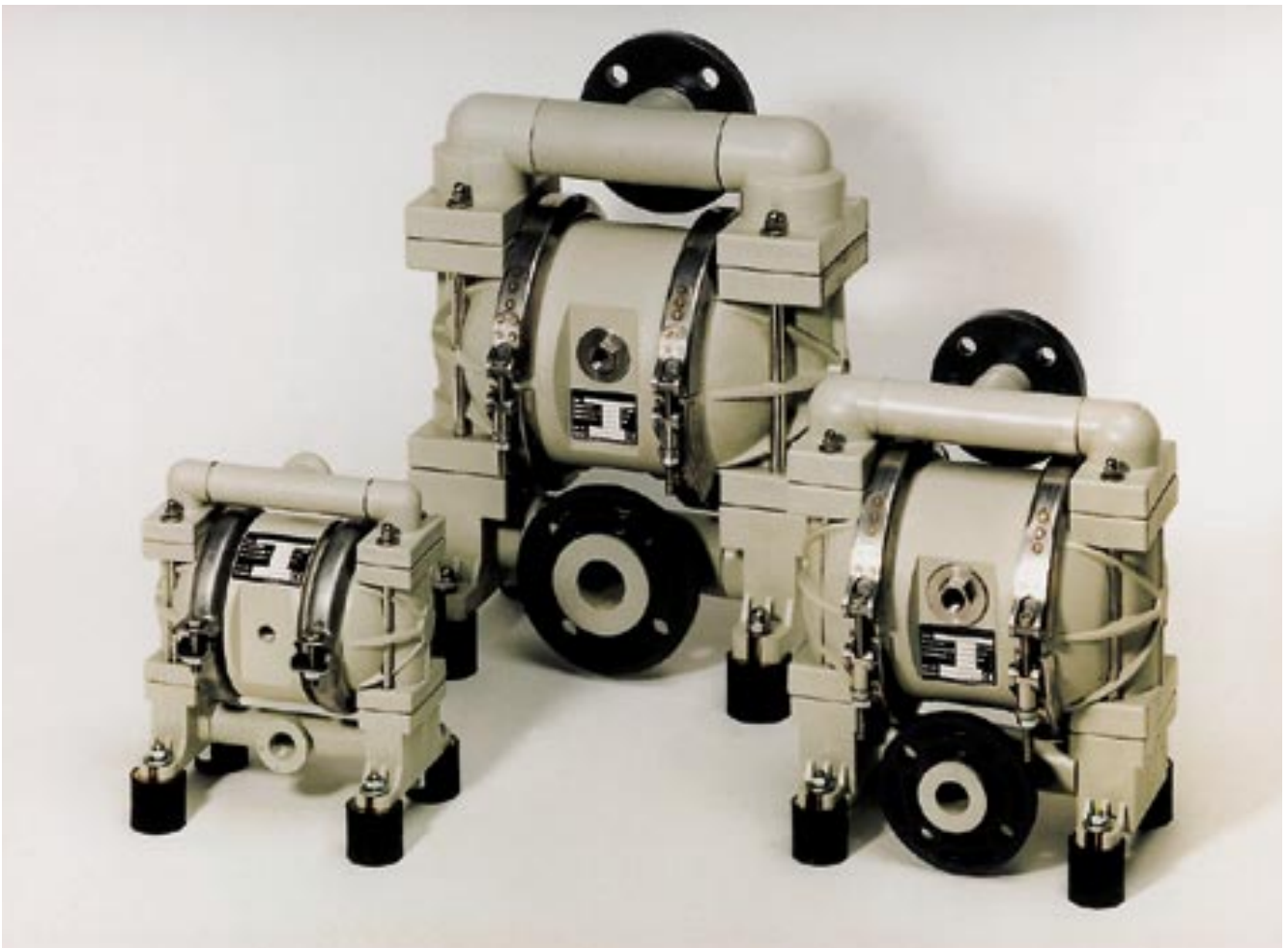

DEPA Air Operated Diaphragm Pumps

Series P Plastic Pump Type DL15-PM



Technical Specification

Product wetted parts

Housing material: PPH injection moulded
 Elastomer material: NRS, NBR, EPDM, FKM, PTFE for diaphragms, valve seats, balls
 Suction and discharge connection: R 1/2", female thread

Non-wetted parts

Centreblock material: PP
 Air valve internal: brass, brass nickel plated
 Product temperature max.: 60 °C
 Suction lift max.: 2.5 m
 Solid size max.: Ø 2.5 mm
 Pump weight: 3.5 kg
 Flow rate: 2,2 m³/h at 7 bar max.

Performance curves

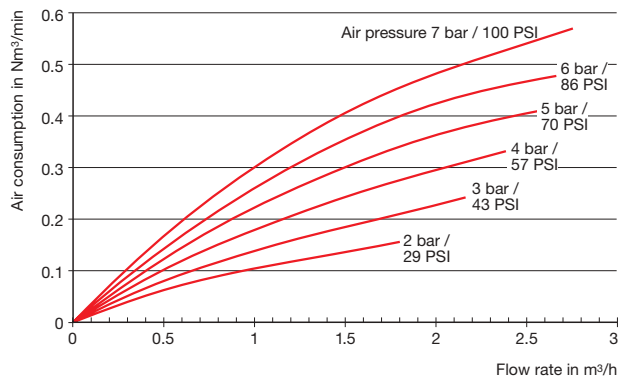
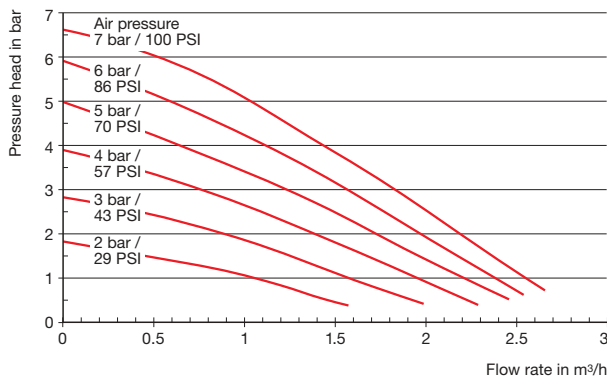

Dimension drawing

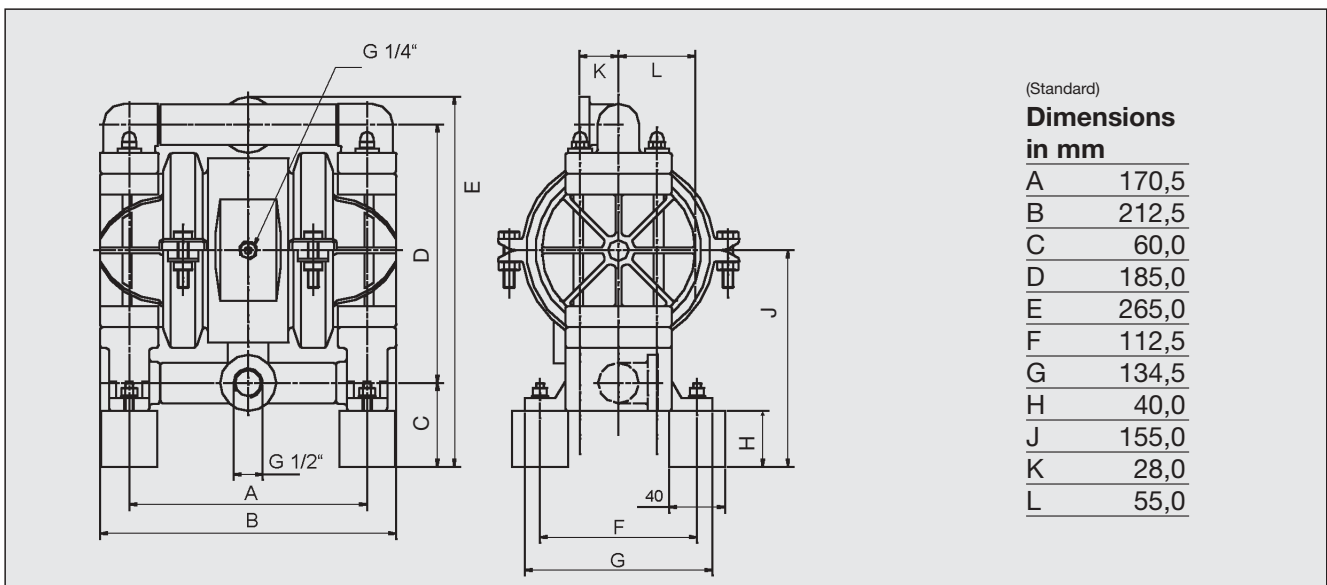

DEPA Air Operated Diaphragm Pumps

Series P

Plastic Pump Type DL25-PM



Technical Specification

Product wetted parts

Housing material: PPH injection moulded
 Elastomer material: NRS, NBR, EPDM, FKM, PTFE for diaphragms, valve seats, balls

Suction and discharge connection: Standard PVC-Loose flange DN 25 DIN 2653, special options Combined DIN/ANSI, ANSI-, JIS-Flange or R1" female thread

Non-wetted parts

Centrebloc material: PP
 Air valve internal: brass, brass nickel plated
 Air valve external: coated
 Clamp band: 1.4301
 Product temperature max.: 60 °C
 Suction lift max.: 4 m
 Solid size max.: Ø 4 mm
 Pump weight: 8.4 kg
 Flow rate: 6,6 m³/h at 7 bar max.

Performance curves

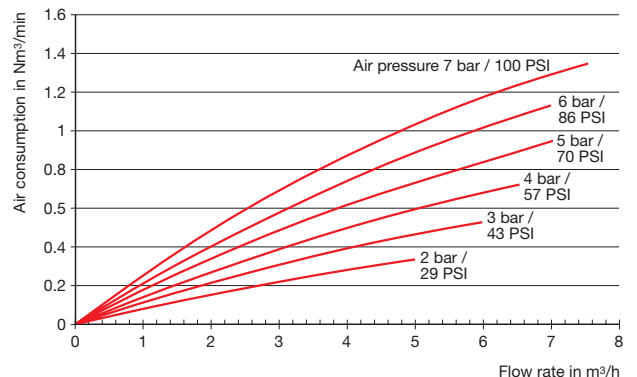
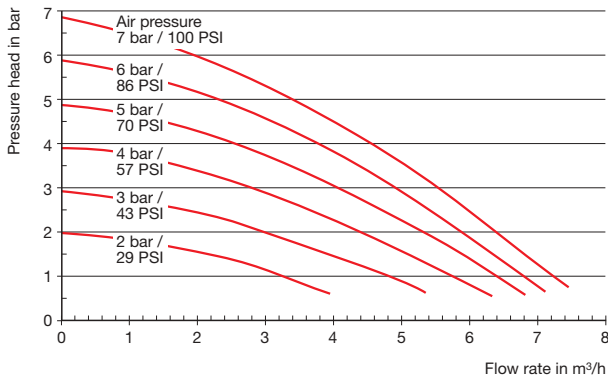

Dimension drawing

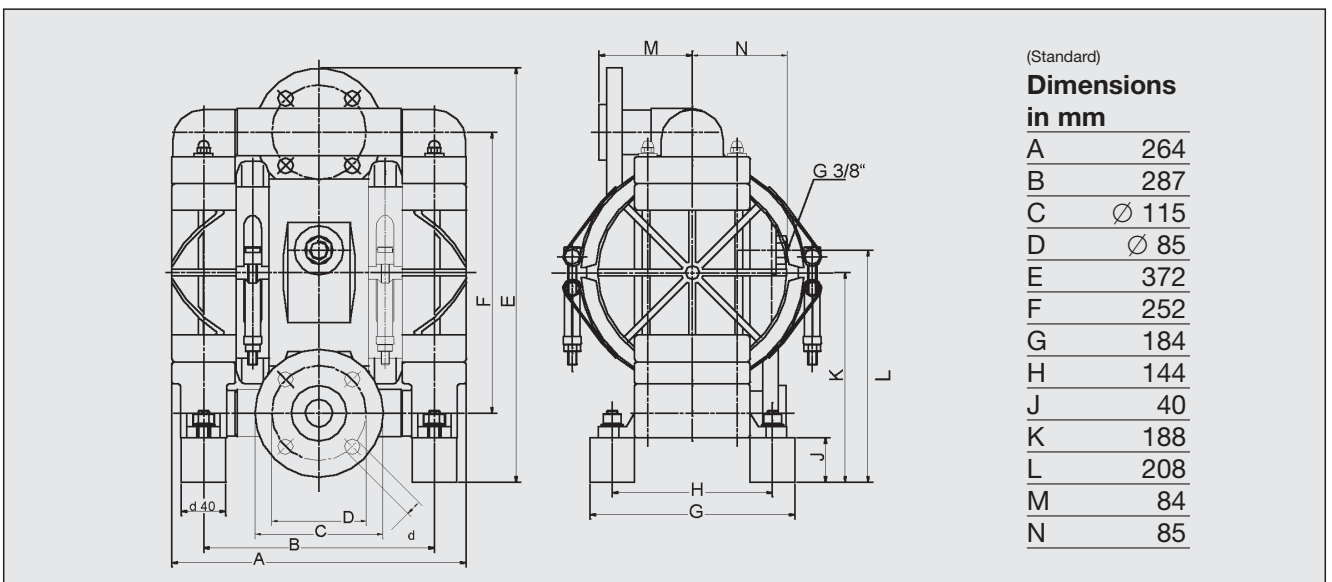

DEPA Air Operated Diaphragm Pumps

Series P Plastic Pump Type DL40-PM



Technical Specification

Product wetted parts

Housing material:
Elastomer material:

PPH
NRS, NBR, EPDM, FKM, PTFE
for diaphragms, valve seats and balls

Suction and discharge
connection:

Standard PVC-Loose flange DN 40
DIN 2653, special options Combined
DIN/ANSI, ANSI-, JIS-Flange or R1½"
female thread

Non-wetted parts

Centreblock-material:
Air valve internal:
Air valve external:
Clamp band:
Product temperature max.:
Suction lift max.:
Solid size max.:
Pump weight:
Flow rate:

PP
brass, brass nickel plated
coated
1.4301
60 °C
5.5 m
Ø 6 mm
15.1 kg
9 m³/h at 7 bar max.

Performance curves

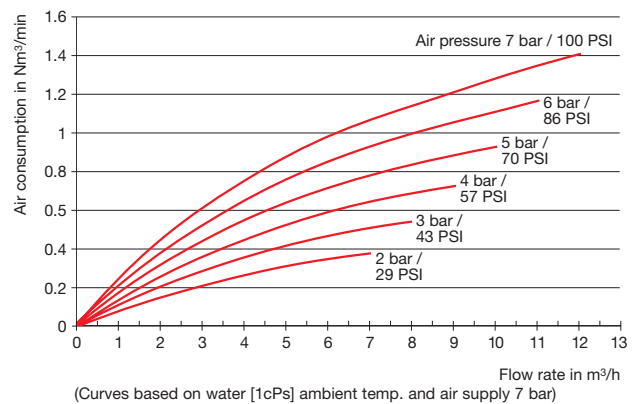
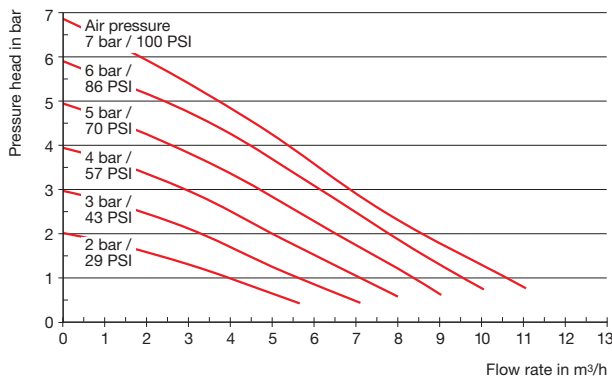

Dimension drawing

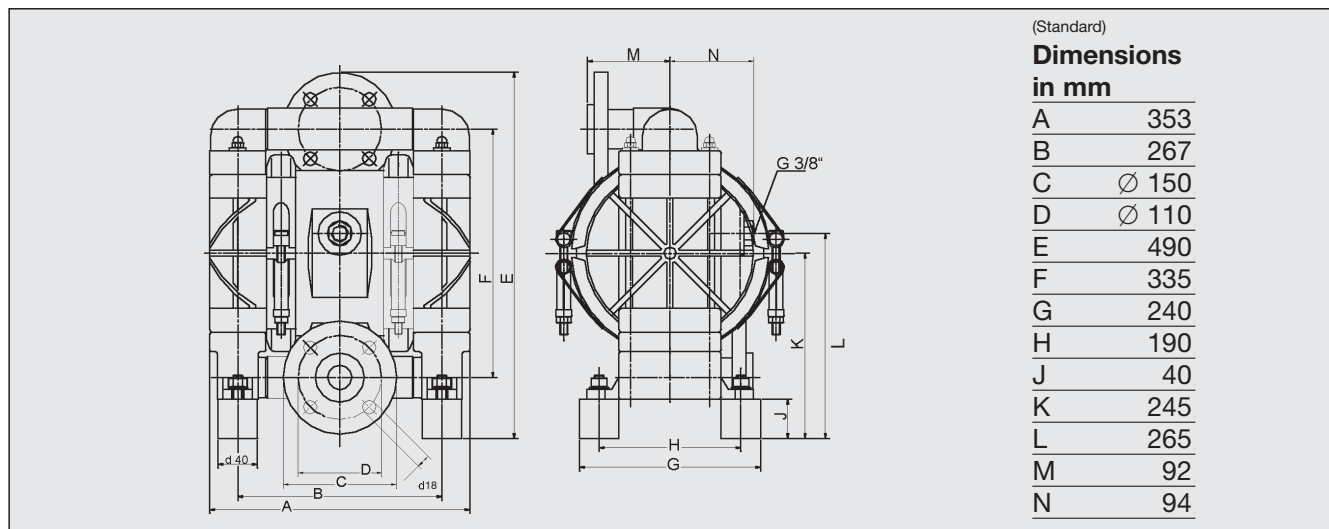

CRANE®