

DEPA Air Driven Diaphragm Pumps

Series DP 50 +80 Powder Pumps

DEPA Series DP pumps are manufactured in three sizes, in a variety of materials such as polished stainless steel, aluminium and cast iron, to suit a variety of applications for powder conveying. These pumps employ the well established operating principle of DEPA air operated diaphragm pumps.

In developing the optimum DEPA pump to fulfil the requirements of powder transfer, the suction and discharge manifolds of the DP Series have been designed with a “Y” configuration in order to minimise bends and curves and provide as smooth a flowpath as possible. This arrangement takes up more space than the standard DEPA manifold design but makes a dramatic improvement to the flow characteristics of the powder through the pump.

All DP Series pumps have connections that allow fluidising equipment such as aeration valves to be used. When pumping product from open containers, a suction lance is normally attached to the suction hose to allow fluidisation of the product. To ensure long term dependable operation, the product should be properly fluidised. Granules or crystalline media can only be pumped under certain conditions—please check with your DEPA supplier. Bulk density of the powder must not exceed 500 gm/l and the particle size must be under 100 μ (microns).

The values given are for guidance only. Under some circumstances, if special precautions are taken, they can be exceeded.

Reliable Operation

On the suction side, DEPA Series DP air operated diaphragm pumps operate in principle like vacuum cleaners. Then, the product enters the suction chamber and is discharged on the next stroke.

- DEPA powder pumps are portable and mobile.
- Low product velocities, compared with other methods of powder pumping, result in gentle product handling.
- Lower cost and more efficient powder transfer than mechanical methods.
- Because of the low air to product ratio (typically 1:3 to 1:5), less air need be extracted on the discharge side.

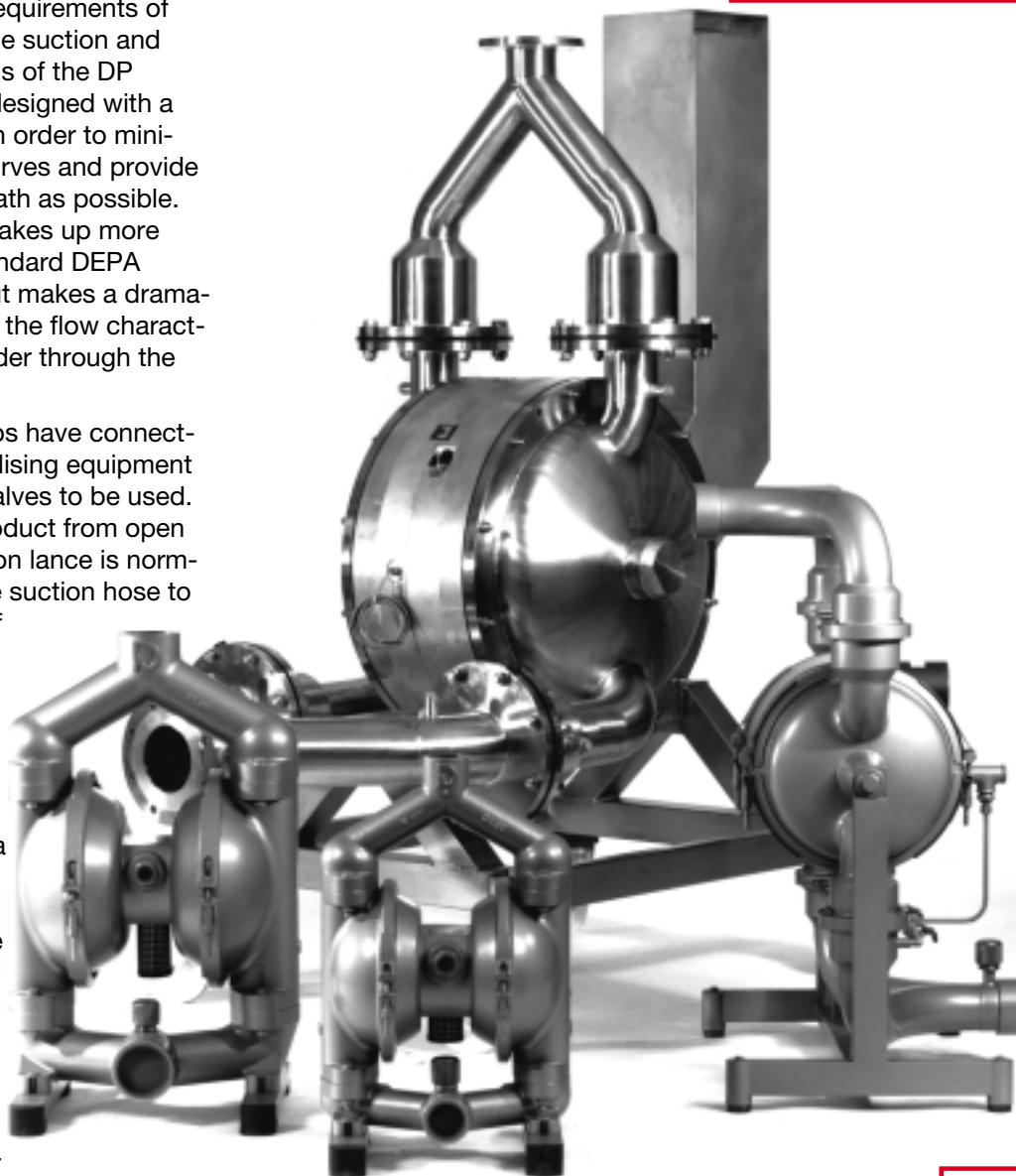

Dimensions

Dimensions for all sizes of DEPA Series DP powder pumps. All dimensions in mm. The dimensions are for guidance only and should not be used for installation purposes. Certified dimensions will be supplied on request.

Series DP 50 and 80

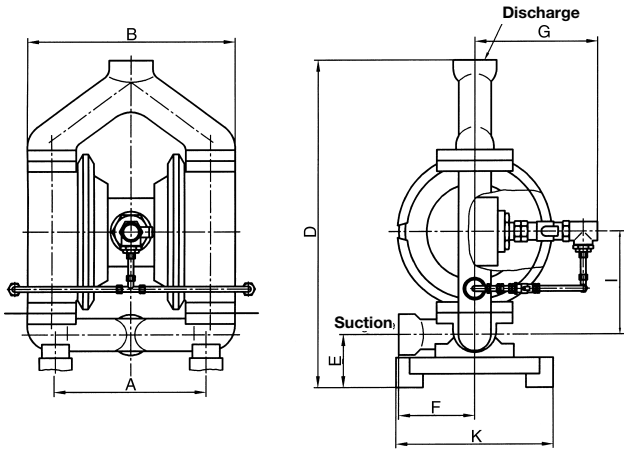

Pump	A	B	D	E	F	G	I	K	Suction Side	Discharge Side
DP 50	280	412	658	88	145	175	245	340	R 2 in.	R 2 in.
DP 80	350	512	810	105	180	175	304	420	R 3 in.	R 3 in.

Type DP 80 SA

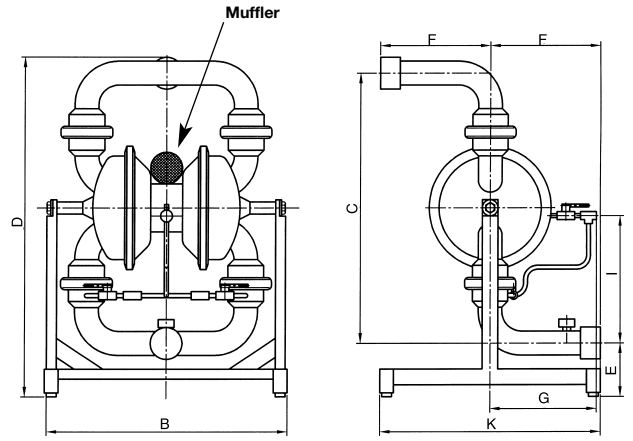

B	C	D	E	F	G	I	K	Suction Side	Discharge Side
755	1035	1100	110	300	320	425	490	R 3 in.	R 3 in.

See Note 1

Note 1. Muffler option available